

# MAINTENANCE SWITCH



**FIGURE 1. PRODUCT PICTURE**

This MAINTENANCE panel is a key switch, which disconnects actuation circuits in the system to prevent accidental discharge during maintenance operations.

Two "LEDS" indicate "SYSTEM ARMED" and "SYSTEM INACTIVE". When the key is inserted and turned towards "SYSTEM INACTIVE", the red LED illuminates and the green LED indicating "SYSTEM ARMED" turns off. The key can only be removed in the "SYSTEM ARMED" position.

This panel is also available with the key removable in both the "ARMED" and the "INACTIVE" positions.

The information is silk-screened on a two-gang stainless plate.

Switch rated at 5A 250VAC, the DC rating is 5A up to 30VDC.

LEDS rated at 10mA each for a total current draw of 20mA.

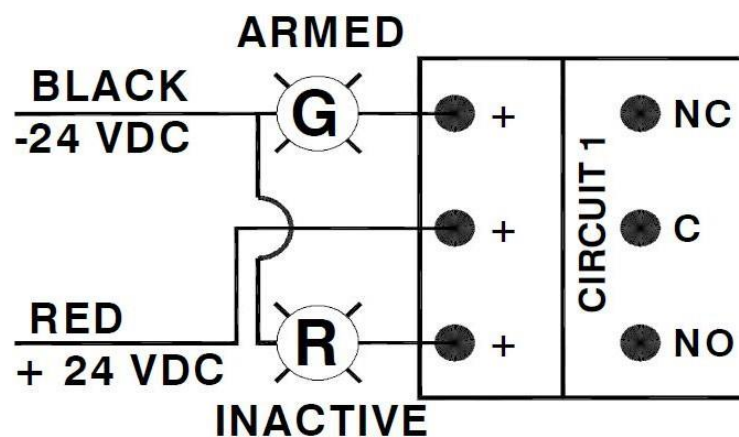

**FIGURE 2. WIRING DIAGRAM**